

S-Band Patch Antenna

DATASHEET

ISIS-QMS-TPL-0045, version 0.0

CubeSat S-band patch antenna

Applications

The ISIS S-band patch antenna is a compact, low mass solution suitable for the 2200-2290 MHz S-band frequency range. This antenna is suitable for integration on any CubeSat platform and directly compatible with the ISIS S-band transmitter and transceiver products as well as ISIS standard CubeSat structures.

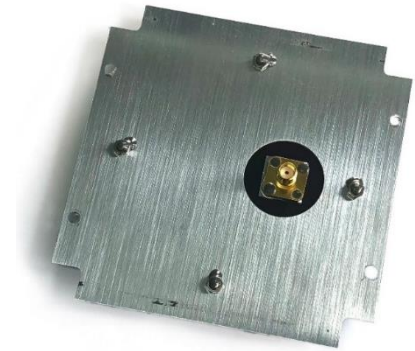

General description

The ISIS S-band patch antenna is part of a new generation of antennas designed for S-band communications on nanosatellites and CubeSats. It is an off the shelf compact antenna designed to complement ISIS S-band radios for telemetry and payload data transmission.

Compatibility

- Compatible with ISIS CubeSat structures, designed to fit on a 1U face or on a "Tuna can".
- Compatible with ISIS S-band radio products

Flight heritage and quality assurance

- Qualification tested for quasi static acceleration to 15g in three axes.
- Flight units thermally acceptance tested for workmanship.
- IPC-A-610 Class 3 PCB and assembly.

Product features

- Covers the 2200-2290 MHz EESS/SRS/SOS S-band allocation
- Light weight solution <50g
- Can be supplied with CubeSat compatible mounting panel
- Compatible with mounting onto CubeSat "Tuna can"
- Maximum gain up to 6.5 dBic
- 100° Half Power Beam Width
- Single straight SMA connector (right-angle connector available as option)
- Right Hand Circular Polarization

Ordering information

Please contact sales@isispace.nl for ordering information

Specification

Table 1 SSPA Specification

Parameter	Typical Value	Units
Environmental Characteristics		
Operational temperature	-20 ... +50	°C
RF Characteristics		
Frequency Range	2200-2290	MHz
Gain in boresight (centre frequency)	6.5	dBic
Half Power Beam Width	100	° (degrees)
Return Loss (across frequency range)	> 13	dB
Bandwidth:	> 100	MHz
Axial Ratio	< 3 (for +/-100 degrees)	dB
Polarization	RHCP	-
Power handling	2	W
Physical Characteristics		
Mass	< 50	g
Diameter	80	mm
Height (without connector)	5.0	mm
Connector height (straight)	8.8	mm
Interfaces		
Mechanical interfaces	4 x M2.5	-
RF connector	50Ω SMA female Orientation: straight (default), right angle (optional)	-

RF Description

Radiation Pattern

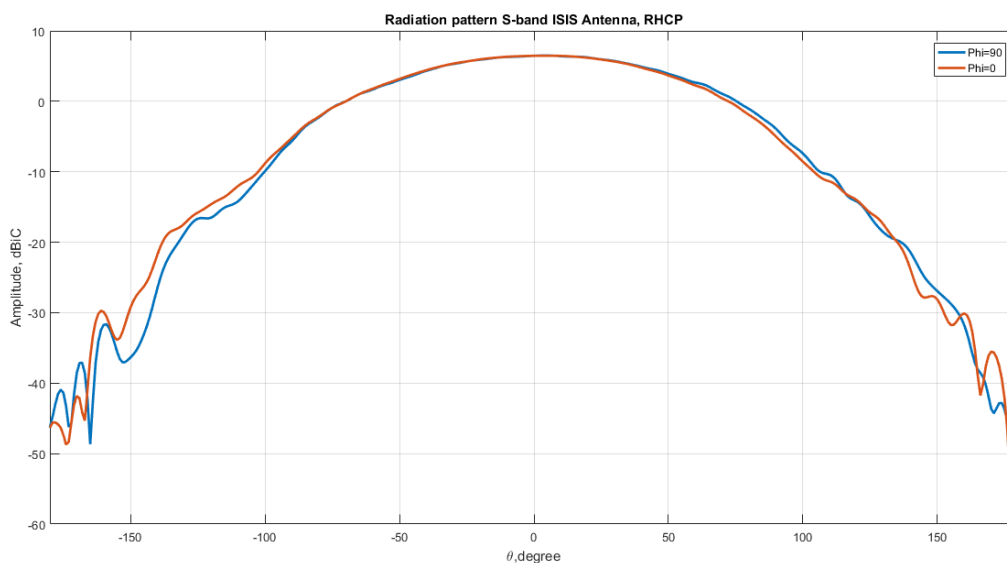
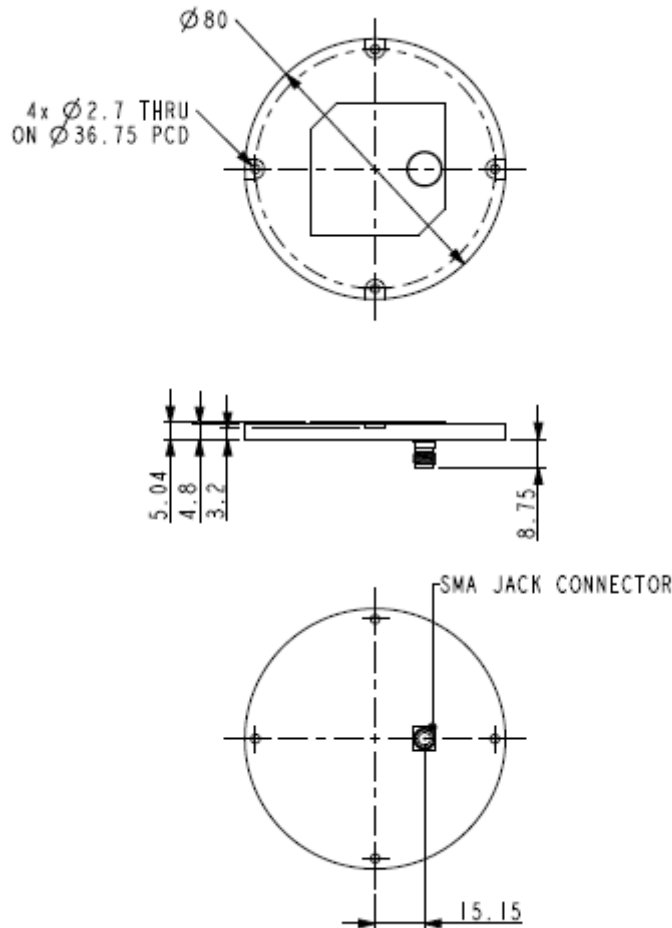

Figure 1 Typical co-polar radiation pattern at 2245 MHz

Mechanical Description

Mechanical Outline



Detailed interface information and CAD models of the entire **AAA** may be delivered on request.

Disclaimer

The contents of this document are subject to the relevant provisions in the contract concluded between the parties. ISISPACE Group ("ISIS") shall not be liable, in full or in part, for any damage arising out from the application or use of any product or circuit described herein, in case such application or use are carried out in a manner not in line with the instructions and warranties provided in the User Manual, Safety Manual, product information sheets or any other document provided by ISIS upon the delivery of the product ("Documents"). Further, ISIS shall not be liable for any damage caused by any use which exceeds the function(s) of the product, or does not conform to such function(s) as described in the Documents. ISIS shall not be liable for any damage arising from a use which is not carried out in a manner conforming to acceptable practices in the aerospace industry.

ISIS warrants that the product is supplied after relevant tests had shown the product is in good order and functioning, as far as these tests may indicate and predict product functionality.