

Deployable Antenna System

DATASHEET

ISIS-ANTS-DSH-0001, version 4.0

Innovative, deployable upon command and compact Antenna System specially designed for CubeSat missions.

Applications

CubeSat TT&C
 CubeSat RF Payloads

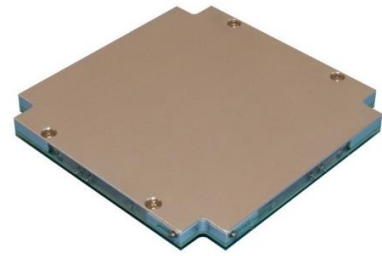

General description

The ISIS deployable antenna system contains up to four tape spring antennas of up to 55 cm in length in the case of VHF and up to 17 cm in length in the case of UHF, which deploy from all four sides of the box upon command.

The deployment of each antenna is achieved by melting a small wire which holds down the lid of its antenna box. The wires are melted using two redundant heating elements per wire, controlled by two redundant microcontrollers.

Once the antennas deploy, the microcontroller gets a feed-back from the feed-back switches, providing a reliable feedback about the status of deployment.

Optional features

- Supply Voltage 5V available on demand
- 30 mm diameter centre through-hole for pass-through of payload or other interfaces (for mono/dipole configurations)
- Solar panel on top
- ADCS sensor set (sun sensor/temps sensor)

Compatibility

- Designed for combination with the ISIS TRXUV VHF/UHF Transceiver.

Flight heritage and quality assurance

- Design based on heritage from the Delfi-C3 satellite (2008).
- Flight heritage since July 2010.
- Qualification Thermal Testing, -40 to +80 °C.
- Design qualification load Static +10.8 [g], three axes.
- Sine and Random Vibration ASAP5 Qualification Levels.
- Flight units thermally acceptance tested for workmanship.

Ordering information

Please contact sales@isispace.nl for ordering information

Product features

- Various RF antenna configurations:
 - 4 VHF and/or UHF monopoles¹.
 - Single VHF or UHF dipole.
 - Dual VHF and/or UHF dipole.
 - VHF or UHF turnstile.
 - Combination of Dipole + Monopole¹.
- Antenna polarization circular or linear
- Frequency Range: >10MHz useable bandwidth in frequency range specified
- Max RF Power 2W
- Antenna Return Loss at resonance frequency >10dB (VSWR <1.9:1)
- Power Consumption:
 - Nominal < 40mW
 - During Deployment 2W (< 1Sec per antenna at 25 °C)
- Supply Voltage 3V3 with a specified range of 3 to 3.6V
- Deployment feedback switch per antenna
- I2C Interface
- Software safe/arm implementation
- Dual redundant deployment system
- Operational Temperature Range: -20 to 60 °C²
- Envelope stowed (l x w x h): 98 x 98 x 7 mm (supplied aluminium cover plate included)
- Mass < 100 gr
- RF input / output 1- 4 MMCX/SSMCX, female, 50 Ohm
- Miniature 9 pin OMNETICS® connector for power and data interfaces.
- Compatible with ISIS products and recent Pumpkin³ and GomSpace products.
- Compliant to CubeSat standard.

¹ Not all combinations are possible in this configuration, please check with the sales engineer for the feasibility.

² All antennas produced as FM undergo at-least two thermal cycles and thermal soaking at the extreme temperatures for at-least 45 min.

³ *: Compatible with Pumpkin Cubesat Rev D (Top & Bottom), Rev C (Bottom only). Not compatible with other Pumpkin structures and Solar Panel clips on Pumpkin structures.

Block Diagram

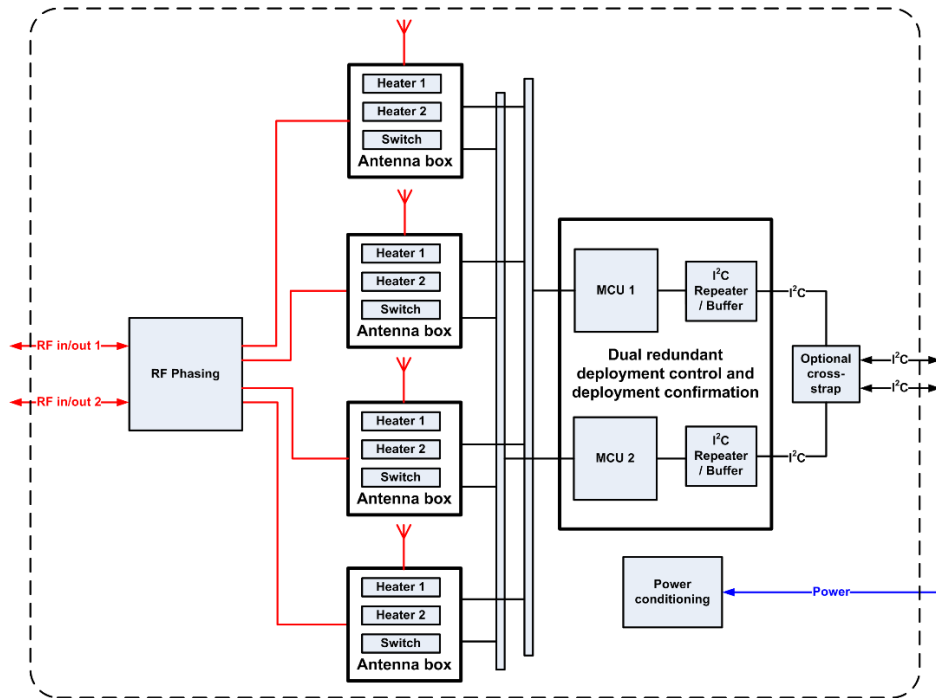

Figure 1 AntS General block diagram

Specification

Table 1 AntS Specification

Parameter	Typical Value	Comments
Environmental Characteristics		
Qualified operational temperature range	-20 to +60°C	
Storage temperature range	-30 to +70°C (RH<60%)	
Electrical Characteristics		
Supply Voltage	3.0V to 3.6V (3.3V nominal) 5.0V (on customer request)	
Typical current consumption (antennas stowed)	13mA @ 20°C	
Typical current consumption (antennas deployed)	11mA @ 20°C	
Typical deployment current (for each element)	0.55A @ 3.3V 0.375A @ 5.0V	
Typical deployment duration (per antenna at temp >0°C)	<3s	
Safety Time limit	30s	
Physical Characteristics		
Dimensions (Main)	98 x 98 mm	
Dimensions (Extending fasteners)	102 x 102 mm	
External height	6 mm	
Internal envelope	3.0 mm	
Weight	89 grams	

Parameter	Typical Value	Comments
RF Characteristics		
Antenna Return Loss at resonance frequency (with antenna elements deployed)	> 10dB	

Functional Description

The AntS provides a configurable antenna deployment system with a configurable user interface. The AntS can house up to four antenna strips which may be tuned for typical VHF and UHF frequencies in use by nano satellites as required by the user. The antennas may be configured for various RF configurations (up to four monopoles, up to two dipoles, one turnstile or a combination of one dipole and up to two monopoles) and are deployed automatically or under user command by a redundant control mechanism.

Arming and disarming

In order to prevent the antennas from accidentally deploying, the system has an armed and disarmed state. The deployment systems for the antennas can only be activated when the system has been armed. The antenna system can be armed using an I²C command.

Antenna deployment switches

The deployment system of each antenna is equipped with a switch. The function of this switch is to detect whether the antenna is deployed or not (also referred to as stowed). The switches are connected to both microcontrollers in the antenna system, which allows their status to be read out using I²C.

Activation safety time limit

In order to prevent the deployment systems from being active too long a safety time limit has been built into the system. Having the deployment system active too long could result in damage to the deployment system itself, which would prevent reuse. Reuse might be required if it's unclear whether the antenna has deployed or not and another deployment attempt has to be performed. The safety limit is also in place to prevent the deployment systems from draining the satellite's batteries when accidentally activated for too long. By default, it's 30 seconds.

Activation tracking

For each deployment system the following information is stored in the microcontroller:

- How many times has the deployment system of the antenna been activated.
- How long in total has the deployment system been active. This is added up over multiple activations.

This information is available from the microcontroller upon request and can be used to determine how long it took for antenna to deploy. Please note that this information is lost whenever the microcontroller experiences a reset.

Power Conditioning and Distribution

The Ants is powered by a 3.3V or 5V supply line from the satellite EPS. During the brief period of antenna deployment, the AntS required approximately 2W of electrical power. After deployment the system may be permanently switched off by the satellite EPS to save power.

The burn time required per antenna element deployment at 20°C is typically less than 3s. For deployment at very high temperature this would be shorter (<1s at 80°C) while for very cold temperatures this would be longer (<20s at -40°C).

There are two redundant power connections on the 9pin connector (Omnetics Bi-Lobe PN: A29100-009).

Electrical Description

The AntS electrical architecture is described in Figure 2 for the non-RF components.

- The AntS is controlled by dual redundant microcontrollers which may be interfaced to the satellite bus using the I²C protocol. Bus speeds up to 400kbps and 3.3V voltage levels are supported. A unique I²C addresses will be provided for each processor.
- Antennas are deployed by burning a wire as described above.
- Antenna status (stowed or deployed) is measured using switches.
- One I²C repeater is used for each data bus in order to provide better isolation and robustness of the I²C bus.
- Two temperature sensors are present on the board.

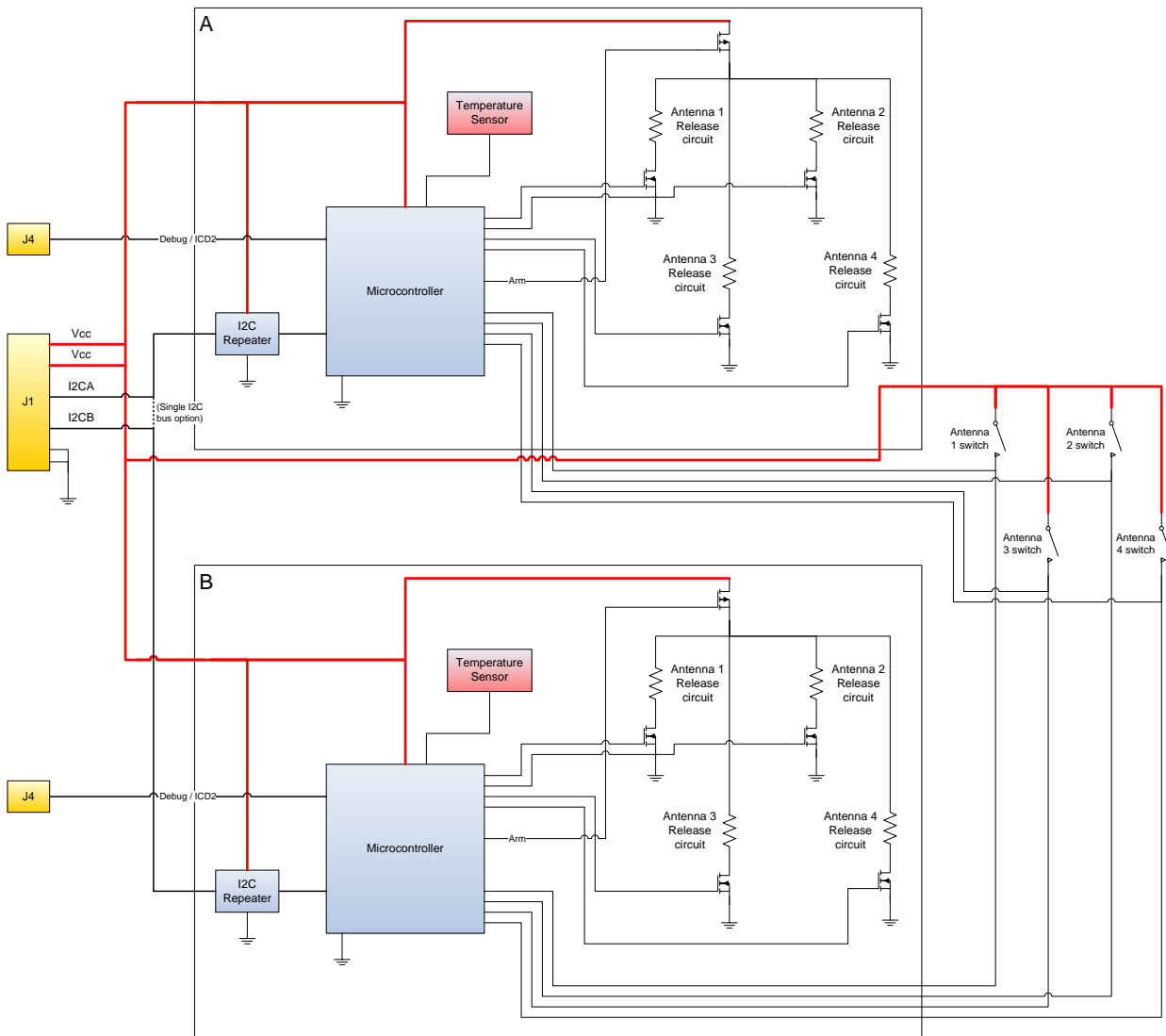

Figure 2 AntS Electrical block diagram (no RF)

The electrical interface consists of a single 9 pin connector (Omnetics Bi-Lobe PN: A29100-009) carrying all required signals. Supply voltage, ground and I²C data bus signals are routed through redundant pins.

Detailed interface information and CAD models of the entire AntS may be delivered on request.

RF Description

Figure 3 shows the RF components of the AntS. Depending on the antenna configuration option, different components are used on the PCB as described in Table 2.

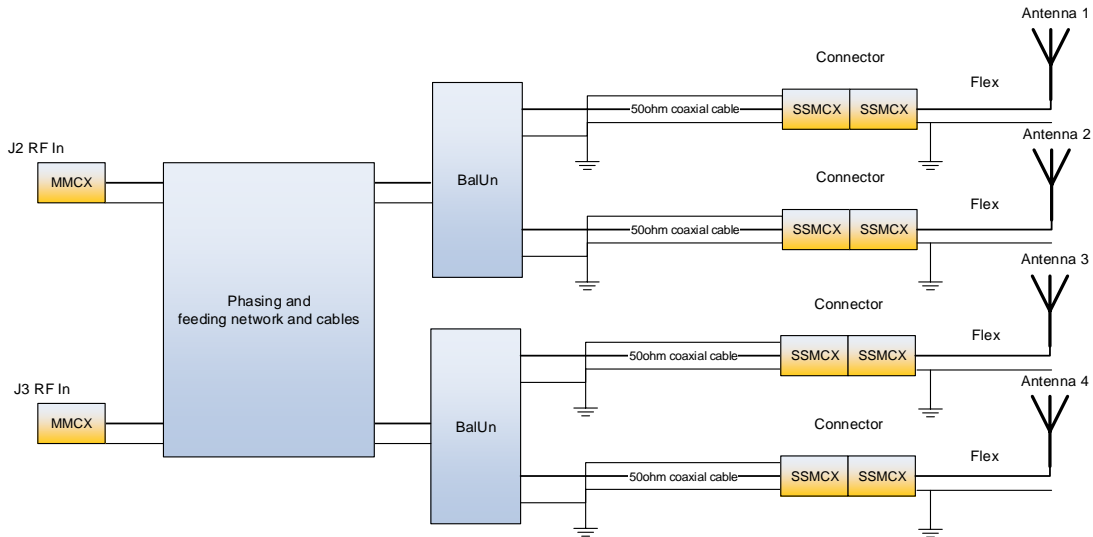

Figure 3 AntS RF block diagram

For the turnstile configurations the antenna may be configured for right hand (default) or left hand circular polarization depending on the physical connection of the phasing cables. For the dipole and turnstile configurations, phasing lines and baluns are implemented on the AntS Motherboard. For the monopole configuration, the antennas are fed directly from the flex-rigid PCB and no RF components are used on the AntS Motherboard. Note that combinations of UHF and VHF dipoles and monopoles are possible to be implemented on a single AntS PCB but the effect of the custom configurations on the resonance tuning needs to be taken into account during the tuning process.

Table 2 AntS RF Configurations

RF Configuration	90Deg phase shifter	RF Ports	Polarization	Elements in use	Number possible per AntS
UHF Turnstile	In use	J2 or J3 (MMCX female)	Circular	4	1
VHF Turnstile	In use	J2 or J3 (MMCX female)	Circular	4	1
UHF Dipole	Not Used	J2 or J3 (MMCX female)	Linear	2	2
VHF Dipole	Not Used	J2 or J3 (MMCX female)	Linear	2	2
UHF Monopole	Not Used	Flex Connectors (SSMCX female)	Linear	1 up to 4	1 up to 4
VHF Monopole	Not Used	Flex Connectors (SSMCX female)	Linear	1 up to 4	1 up to 4

The RF impedance of all connectors is 50 ohms with a S11 greater than +10dB and the maximum RF power handling on all RF ports is 2W.

[Detailed interface information and CAD models of the entire AntS may be delivered on request.](#)

Grounding Scheme

There are three redundant ground connections on 9pin connector (Omnetics Bi-Lobe PN: A29100-009) with common system ground used.

[Detailed interface information and CAD models of the entire AntS may be delivered on request.](#)

Mechanical Description

The ISIS Antenna System (AntS) design is fully compatible with the CubeSat standard as defined by CalPoly and compatible with ISIS & Pumpkin CubeSat structures. When delivered, the AntS is already fully assembled and nearly all fasteners are locked with torque and Epoxy (3M Scotchweld 2216). Exceptions are the fasteners holding down the cover lid and the fasteners which need to be accessed by the customer to allow integration with the customer satellite.

The antenna system consists of up to four antenna elements which are rolled-up and stowed inside the antenna housing. An aluminium bracket creates an enclosure in which the antenna is stowed and contains a Polycarbonate lid to release and deploy the antenna in orbit.

The Antenna elements are made out of a NiTi-alloy based shape memory alloy in order to reduce the required antenna envelope in stowed configuration. The antenna is connected to a SSMCX connector through a flex-rigid PCB.

The lid is kept close with a spring tensioned burn wire which is made from dyneema wire. The wire is routed over a set of redundant resistors which can be heated on command, which melts the wire and releases the lid.

The overall height of the AntS is build up by a 1mm PCB, 4.1mm mechanical parts and an aluminium lid of 0.8mm (which is delivered as standard with every unit shipped) for a total of 5.9mm. The AntS has a mass of less than 100g and a COM close to the physical centre of the module.

[Detailed interface information and CAD models of the entire AntS may be delivered on request.](#)

Software

Functions/Commands

The ISIS Antenna System contains the following functionality:

- Active commands:
 - Arming and disarming the antenna system
 - Activate/deactivate the burn mode of the AntS
 - Activate individual burn resistors or an automatic burn sequence deploying all four antennas in sequence.
 - Deployment of individual antennas
 - Automated sequential antenna deployment
 - Storage and reporting of activation count and total activation time
- Telemetry retrieval:
 - Device uptime.
 - Current version of the microcontroller firmware
 - On-board temperature
 - Deployment status of each of the four antennas.

- Total burn time (stored in non-volatile memory) of each of the four antenna deployment resistors.
- Total number of confirmed deployments (stored in non-volatile memory) of each of the four antenna deployment resistors.
- Reporting system temperature

Please note that all the commands are available on both the A and B microcontroller. Since these are completely separate and independent, commands sent to the A side microcontroller will not affect the B side microcontroller. For example, arming the antenna system through the A side microcontroller will only allow the A side microcontroller to deploy the antennas.

Commands can have responses (return values). These responses need to be retrieved from the controller using a separate data transfer (master read) following the data transfer that contained the command (master write). The response of a command will be generated at the time of reception of the command and not at the time the response is retrieved from the transceiver. This applies for example to the commands of the antenna system to measure the telemetry values: the measurements are performed when the command is received by the antenna system. The response to a command will be available until another command that has a response is executed.

Detailed interface information and CAD models of the entire AntS may be delivered on request.

Disclaimer

The contents of this document are subject to the relevant provisions in the contract concluded between the parties. ISISPACE Group ("ISIS") shall not be liable, in full or in part, for any damage arising out from the application or use of any product or circuit described herein, in case such application or use are carried out in a manner not in line with the instructions and warranties provided in the User Manual, Safety Manual, product information sheets or any other document provided by ISIS upon the delivery of the product ("Documents"). Further, ISIS shall not be liable for any damage caused by any use which exceeds the function(s) of the product, or does not conform to such function(s) as described in the Documents. ISIS shall not be liable for any damage arising from a use which is not carried out in a manner conforming to acceptable practices in the aerospace industry.

ISIS warrants that the product is supplied after relevant tests had shown the product is in good order and functioning, as far as these tests may indicate and predict product functionality.