

Antenna System Electrical Model Datasheet

ISIS.ANTS-ELEC.DS.001, version 2.0

Innovative, deployable upon command Antenna System Electrical Model

Applications

CubeSat TT&C
CubeSat AIV

Product Features

- Power Consumption:
 - o Nominal < 40mW
 - o During Deployment 2W
- Supply Voltage 3V3 with a specified range of 3 to 3.6V
- Deployment simulation easily performed by means of switches.
- Deployment confirmation switch per antenna
- I2C Interface
- Software safe/arm implementation
- Dual redundant deployment system
- Deployment Duration: < 3 s above 15°C
- Operational Temperature Range: -20 to 60 °C
- Miniature 9pin or 8pin OMNETICS® connector for power and data interfaces.

Optional Features

- Supply Voltage 5V available on demand
- ADCS sensor set (sun sensor/temps sensor)

General Description

The ISIS deployable antenna system (AntS) provides a configurable antenna deployment system with a configurable user interface. The AntS can house up to four antenna elements which may be tuned for typical VHF and UHF frequencies in use by nano satellites as requested by the end user. The antennas may be configured for various RF antenna configurations (4 x monopole, 2 x dipole or 1 x turnstile) and are deployed under user command by a redundant control mechanism.

Especially for early software development and mission AIV it was proven convenient to have a version of the AntS without any RF functionality and where the burn mechanism does not perform non reversible burning or burn wires but is simply indicated by indicator LED's. This requirement led to the definition of the AntS-electrical model (ANTS-ELEC) which is described further in this document.

Compatibility

- Compatible with ISIS products and recent Pumpkin and GomSpace products.
- Compliant to CubeSat standard.

Quality assurance

- Units acceptance tested for workmanship.

Ordering information

Please contact sales@isispace.nl for ordering information

Block Diagram

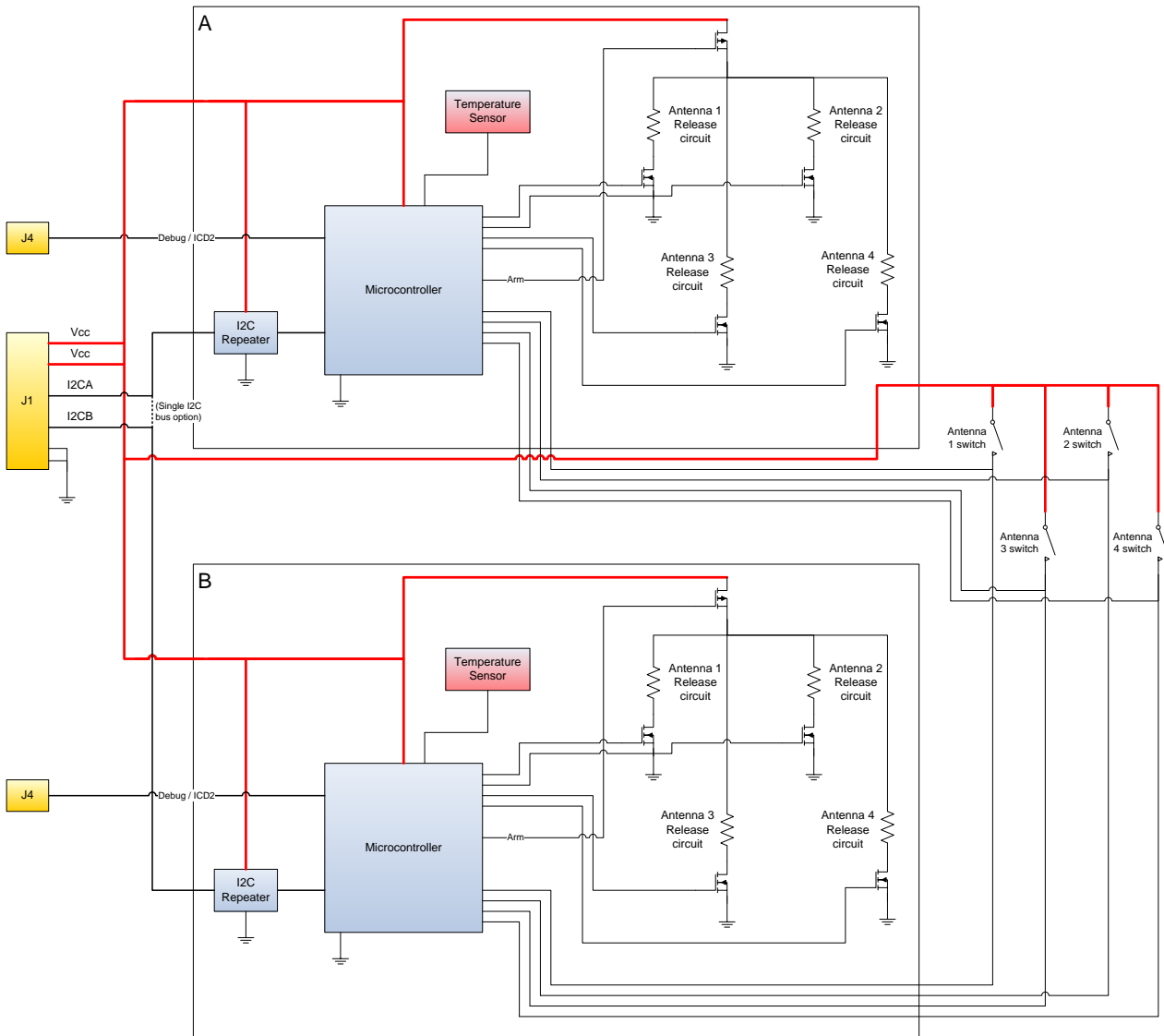

Figure 1 ANTS-ELEC General block diagram

Specification

Table 1 ANTS-ELEC Overall Specification

Parameter	Typical Value	Comments
Environmental Characteristics		
Qualified operational temperature range	-20 to +60°C	
Storage temperature range	-50 to +85°C (RH<60%)	
Electrical Characteristics		
Supply Voltage	3.0V to 3.6V (3.3V nominal) 5.0V (on customer request)	
Typical current consumption (antennas stowed)	8mA @ 20°C	
Typical current consumption (during deployment)	560mA @ 3.3V (20°C) 0.40A @ 5.0V (20°C)	

Table 1 ANTS-ELEC Overall Specification

Parameter	Typical Value	Comments
Typical current consumption (antennas deployed)	7mA @ 20°C	
Physical Characteristics		
Dimensions (Main)	98 x 98 mm	
Overall height	20 to 30 mm	
Weight	30 to 40 grams	

Functional Description

The main functionality of the antenna system is to deploy the stowed antennas so that the antennas can be used for RF transmissions. In the ANTS-ELEC the activation of burn wires and physical deployment of antennas has been replaced by status LED's. Green LED indicators are used for the A-side microcontroller and red LED indicators are used for the B-side microcontroller.

A few of the concepts the system uses will be explained below.

Arming and disarming

In order to prevent the antennas from accidentally deploying, the system has an armed and disarmed state. The deployment systems for the antennas can only be activated when the system has been armed. The antenna system can be armed using an I²C command.

Antenna deployment switches

The deployment system of each antenna is equipped with a switch. The function of this switch is to detect whether the antenna is deployed or undeployed (also referred to as stowed). The switches are connected to both microcontrollers in the antenna system, which allows their status to be read out using I²C. In the ANTS-ELEC the conformation switches are replaced by four deployment simulation switches. The switches have a "Stowed" state that will indicate an "undeployed" condition to the microcontroller and a "Open" state that will indicate a "deployed" status to the microcontroller.

Activation safety time limit

In order to prevent the deployment systems from being active too long a safety time limit has been built into the system. The safety limit is also in place to prevent the deployment systems from draining the satellite's batteries when accidentally activated for too long.

Activation tracking

For each deployment system the following information is stored in the microcontroller:

- How many times has the deployment system of the antenna been activated.
- How long in total has the deployment system been active. This is added up over multiple activations.

This information is available from the microcontroller upon request and can be used to determine how long it took for antenna to deploy. Please note that this information is lost whenever the microcontroller experiences a reset.

Power Conditioning and Distribution

The Ants is powered by a 3.3V or 5V supply line from the satellite EPS. During the brief period of antenna deployment the ANTS-ELEC requires approximately 2W of electrical power.

There are two redundant power connections on 9pin or 8pin connector.

Electrical Description

The ANTS-ELEC electrical architecture is described in Figure 2. The whole deployment system is composed of two fully redundant microcontroller based systems. Antennas deployment is indicated by burning LED indicators as described above. Antenna status (stowed or deployed) is measured using headers and short circuit jumpers. One I2C repeater is used for each data bus in order to provide better isolation and robustness of the I2C bus. Two temperature sensors are present on the board.

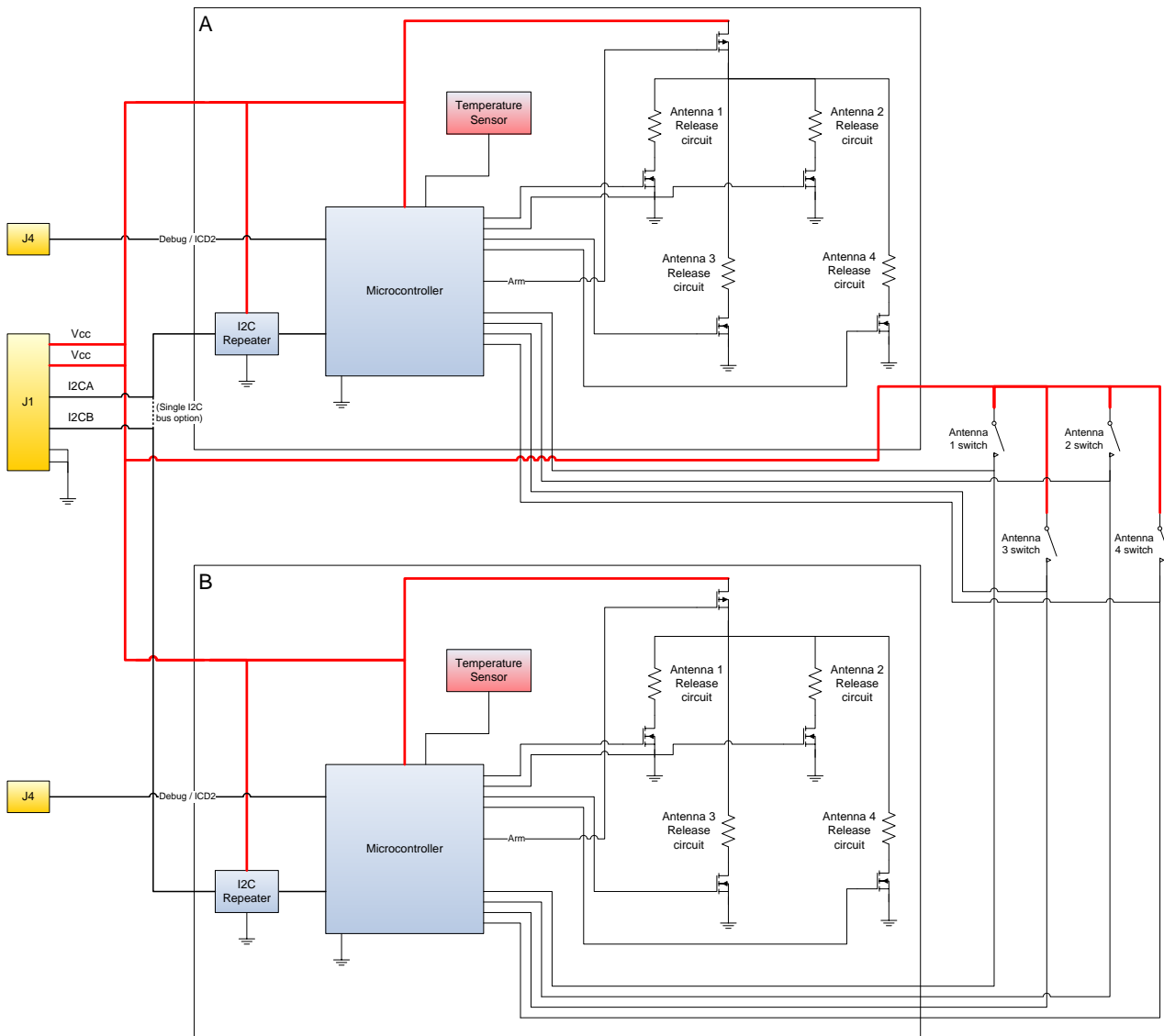

Figure 2 Ants-EM Electrical block diagram (no RF)

Detailed interface information and CAD models of the entire ANTS-ELEC may be delivered on request.

RF Description

No RF Functionality is present on the board.

Grounding Scheme

There are three redundant ground connections on 9pin connector with common system ground used.

Detailed interface information and CAD models of the entire ANTS-ELEC may be delivered on request.



Mechanical Description

The ISIS ANTS-ELEC is designed to be mounted onto the ISIS CubeSat structure with four M2.5x10 CSK Torx screws. The mounting holes for mounting the structures top/bottom panel are used for mounting the ANTS-ELEC module or alternatively it may be used as a loose PCB laying on a table.

Detailed interface information and CAD models of the entire ANTS-ELEC may be delivered on request.

Software

The ANTS-ELEC may be controlled by the satellite command computer sending commands to one or both of the redundant microcontrollers. An illustrative commands set is provided below:

- Activate/deactivate the burn mode of the ANTS-ELEC
- Activate individual burn resistors or an automatic burn sequence deploying all four antennas in sequence.
- Put the ANTS-ELEC processor in sleep mode to limit power consumption.

Status telemetry may be retrieved from the ANTS-ELEC by requesting it from one or both of the redundant microcontrollers. An illustrative telemetry list is provided below:

- Retrieve the current version of the microcontroller firmware
- Retrieve the on-board temperature
- Retrieve the deployment status of each of the four antennas.
- Retrieve the total burn time (stored in non-volatile memory) of each of the four antenna deployment resistors.
- Retrieve the total number of confirmed deployments (stored in non-volatile memory) of each of the four antenna deployment resistors.

Functions/Commands

The ISIS Antenna System Electrical Model contains the following functionality:

- Reporting antenna deployment status
- Arming and disarming the antenna system
- Automated sequential antenna deployment
- Storage and reporting of activation count and total activation time
- Reporting system temperature

Please note that all the commands are available on both the A and B microcontroller. Since these are completely separate and independent, commands sent to the A side microcontroller will not affect the B side microcontroller. For example, arming the antenna system through the A side microcontroller will only allow the A side microcontroller to deploy the antennas.

Commands can have responses (return values). These responses need to be retrieved from the controller using a separate data transfer (master read) following the data transfer that contained the command (master write). The response of a command will be generated at the time of reception of the command and not at the time the response is retrieved from the transceiver. This applies for example to the commands of the antenna system to measure the telemetry values: the measurements are performed when the command is received by the antenna system. The response to a command will be available until another command that has a response is executed.

Detailed interface information and CAD models of the entire ANTS-ELEC may be delivered on request.



Disclaimer

The contents of this document are subject to the relevant provisions in the contract concluded between the parties. ISIS – Innovative Solutions In Space B.V. (“ISIS”) shall not be liable, in full or in part, for any damage arising out from the application or use of any product or circuit described herein, in case such application or use are carried out in a manner not in line with the instructions and warranties provided in the User Manual, Safety Manual, product information sheets or any other document provided by ISIS upon the delivery of the product (“Documents”). Further, ISIS shall not be liable for any damage caused by any use which exceeds the function(s) of the product, or does not conform to such function(s) as described in the Documents. ISIS shall not be liable for any damage arising from a use which is not carried out in a manner conforming to acceptable practices in the aerospace industry.

ISIS warrants that the product is supplied after relevant tests had shown the product is in good order and functioning, as far as these tests may indicate and predict product functionality.